

**INNOVATION
WITH
SIMPLICITY**



A NEW LOOK AND NEW VITALITY

ABOUT TBC

With 30 years of accumulated experience, TBC relocated to its new facility in the Hofa Industrial Park in 2019, successfully increasing production capacity. Recently, the company launched the new high-performance CH series and a 1200-ton large die casting machine to meet customers' demands for high-precision products. TBC has also established a manufacturing base in Gujarat, India, to initiate local assembly and sales operations, bringing the company closer to the market and strengthening its service capabilities.



TBC Taiwan Headquarters



TBC Goldcoin Pvt. Ltd

SERVICE SPOTS



COMPANY PROFILE

THIS IS TBC-DIECAST. INNOVATION WITH SIMPLICITY

Professional Concept and Highly Experienced

Technology Base Corporation was established in 1987, specializing in production and management of peripheral equipment in the die casting industry. TBC focused on the refurbishment and overhauling of die casting equipment. However in 1993, TBC launched its own die casting machine. TBC's first generation machine was a cold chamber die cast machine. TBC's own brand was born. We are constantly challenging ourselves to make more from less without compromising on quality. Customer care is always our top priority.



Renewing and Improving

Having a technical co-operation with the Metal Industries Research and Development Center, TBC was the first die casting machine manufacturer in Taiwan with ISO9001 accreditation.

We are continuously looking for new and better ways forward in research, innovation and personnel training. Finding solutions to seemingly impossible challenges is a source of inspiration to move on to the next challenge.



Valuing Every Individual Diverse Talents

TBC is a team, and as such, we value every individual diverse talents. Working together, with the same goals and direction has become the base for TBC to flourish and improve the quality of our products and service. We dare to push the envelope, to constantly improve ourselves.



An International Outlook and a Global Layout

TBC die casting machines upholds the ideals of stable performance, fine quality and reasonable pricing, which is of course deeply rooted in the minds of customers in the die casting industry field, made known to us after having many years of experience working alongside our customers. We have successfully entered the marketplace in China, India, Vietnam and others. We are actively extending our growth further into the international market to become a global player.



OUR STORY

CHRONICLE OF EVENTS

Technology Base Corporation established in the die casting industry. Specializing in the production and management of peripheral equipment.

TBC began its technical co-operation with Metal Industries Research and Development Center, and began developing new types of cold chamber die casting machines.

TBC obtained ISO9001:1994

CE / CF Series of cold chamber die casting machine was developed and launched.

TBC first generation hot chamber die casting machine was launched and TBC had it's own product and brand.

TBC's new plant, located in HoFa Industrial Park is completed and begins operation.

3rd production base was established in Vadodara (India) & V series of Cold chamber die casting machine was launched.

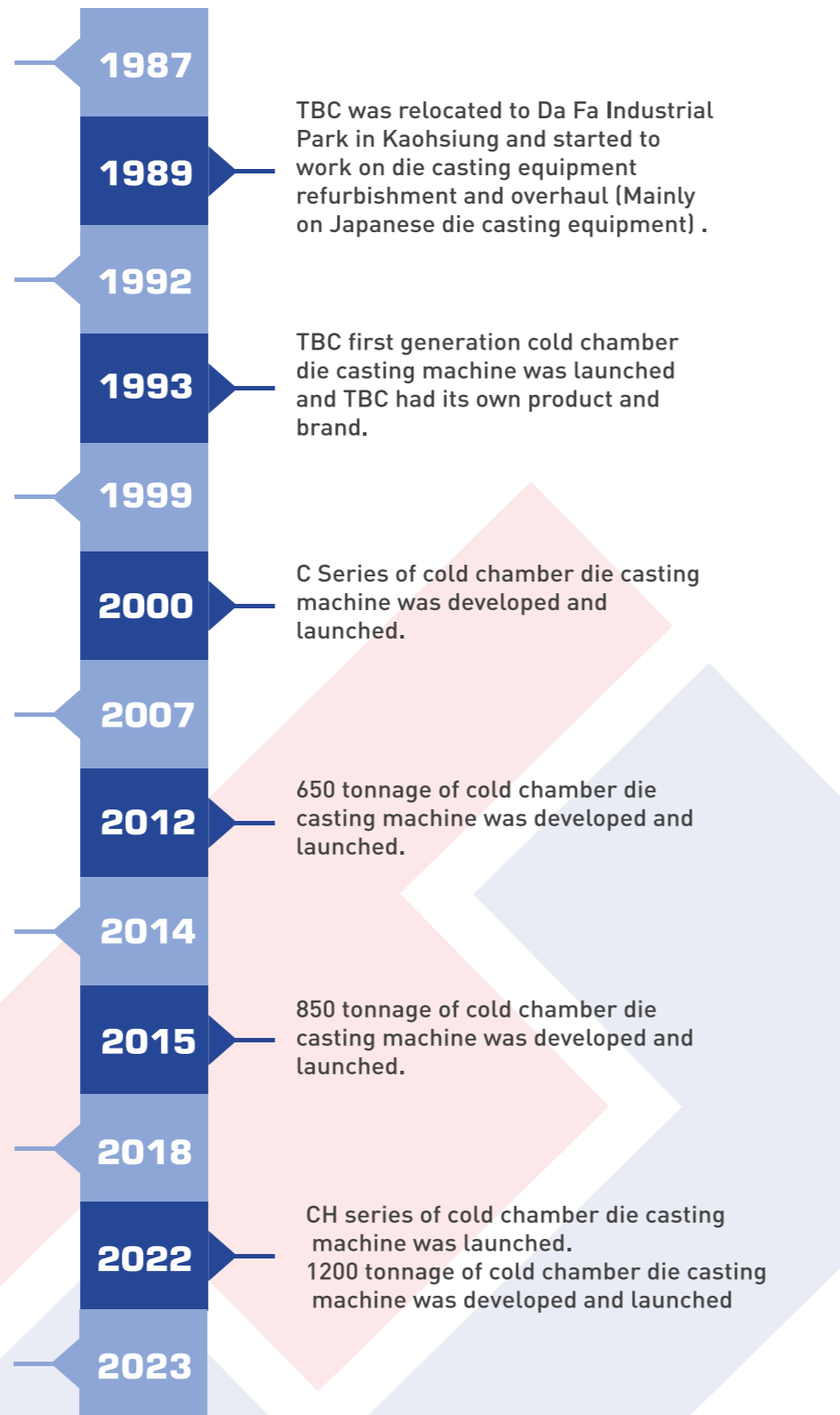

SERVICE ITEMS

DIE CASTING EQUIPMENT

Cold Chamber Die Casting Machine 150-1250ton



- 1.CH/CF/V series.
- 2.150-1250ton

Hot Chamber Die Casting Machine 75-250 ton



1. 75,130,190,250 ton
2. Auto Hydraulic Injection Position Adjustment.
3. Alternative to Gas furnace, Diesel furnace and Electric furnace.

Robot Integration



1. Spraying Robot
2. Extracting Robot
3. Extracting and Spraying (2 in 1) Robot

Auxiliaries



1. Ladler, Sprayer, Extractor
2. Auto Charging System
3. Vacuum System
4. Release Agent Dilutor

TOTAL SOLUTION FOR COLD CHAMBER DIE CASTING MACHINE



Extracting Robot

- Able to be integrated with casting inserts.
- If combined with stamping press/conveyor, improving production efficiency.
- Able to be integrated with Defective Casting Detector, automatically picking out bad castings.



Spraying Robot

- Specialized independent nozzle control for air and release agent.
- Able to adapt to hard to reach angles.
- Spraying parameter stored and is not required copper tubes.
- Able to extend storage space by USB.
- Reduce labor cost.



Release Agent Dilutor

PRODUCTION OPTIMIZATION HELP YOUR DIE CAST TURNKEY SOLUTION



Conveyor



Stamping Press



Auto Charging System (Aluminum/ Zinc)



Melting Furnace for Die Casting

- High melting efficiency and excellent heat preservation.
- Integrated with Furnace Temperature Display, giving alarm if temperature exceeding range of setting.

MODEL & SERIES

COLD CHAMBER DIE CASTING MACHINE / 280-1250ton

CH series	Performance	High Speed Injection	Acceleration
	METER-IN INJECTION SYSTEM	8 m/sec.	80 G

HIGH-END INTELLIGENT MODEL



Energy Saving System: With German Eckerle pump and the whole new controlling system, extend the lifespan and durability.

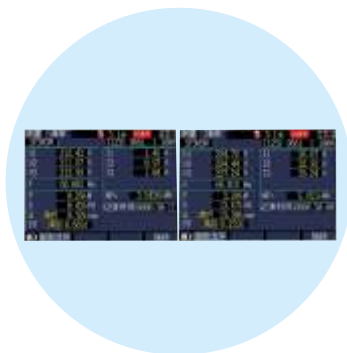

Measurement Comparison(420T)	Power Consumption/ hour	Energy Efficiency
Energy Saving System	3.54x2=7.08	39.5%
Traditional Motor	5.85x2=11.7	0%



High-end Auxiliaries: CH series is equipped with toggle arm ladler, servo sprayer, and servo extractor, highly improving production efficiency and quality.



Dual Hydraulic System and Independent Intensification Accumulator: Owing to the separate ACC for intensification part, the pressure is not influenced by high speed. Moreover, operator can set up IP pressure independently.

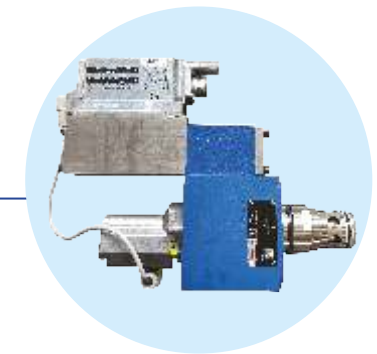

Meter-In Injection System: New hydraulic circuit design is capable to achieve a 80G acceleration and high speed to 8m/s. With German proportion solenoid valve, precisely controlling multi-phase for low speed and reduce casting porosity, higher stability for pressure resistant products and laminar flow die casting. (Low speed setting from 0.05m/s~1.2m/s.)



Advanced Data Management: Standard for die locking force display, abandoned cast setting, detection of defective casting 500 sets of parameter storage.

MODEL & SERIES

COLD CHAMBER DIE CASTING MACHINE / 150-900 ton

CF series	High Speed Injection	Acceleration
	7 m/sec.	60 G

ADVANCED MODEL FOR HIGH PRODUCTIVITY

Smart QC System: Equipped with injection data display, injection diagram, defective detection, oil temperature sensor, oil level sensor (optional), die locking force display (optional).

Assist Production System: Standard for abandoned cast setting, display of injection valve and pressure, timer setting of core position, and shot condition calculation.

Data Storage: 3000 sets of injection data and 300 sets of casting parameters all stored and managed via USB.



Optional for Servo Sprayer: Adjustable for spraying stroke, providing better quality and atomization effect.



Dual ACC and Circuit Design (for 250 ton and above): Efficiently reducing the pressure drop, and providing superior reaction of refilling pressure. More stable in injection.

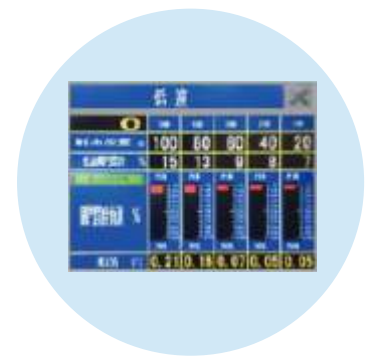

Multi-Speed Injection System: Optional for 5 phase low speed setting, eliminating air entrainment and molten metal flash. Effectively enhancing quality and able to lower porosity.



Back Pressure Relief Device: With unique hydraulic circuit design, acceleration from low to high speed taking only 0.012 seconds.



150CF --14 seconds cycle time

MODEL & SERIES

COLD CHAMBER DIE CASTING MACHINE / 150-420 ton

V

High Speed Injection

5

m/sec.

BETTER SOLUTION FOR COST REDUCTION



HMI Control: Intuitive and ergonomics UI design for controller. 100 sets of parameter storage.



Adjustable Sliding Shoes: Easy to use and enhance the efficiency of platen adjustment.



Auto Lubrication System: Quantitative apply lubrication, preventing toggle pins from locking.



All Production-Related Parameters can be Directly adjusted Or Modified Through the HMI

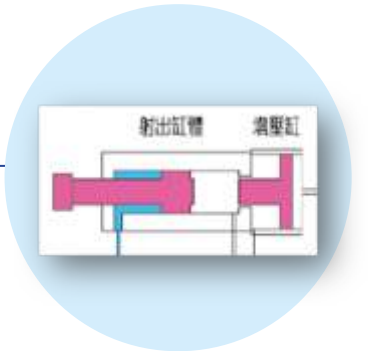

Single pressure dual-cylinder injection system: Paired with a unique hydraulic circuit design, it achieves a high injection speed of 5 m/s, with a transition from low to high speed in just 0.012 seconds.



Injection Valve Setting: Using a traditional rotary dial to adjust the injection valve opening, the mechanical design results in a low failure rate.



SD-1200CF

先進高產能機種、數據管理快速，您的最佳選擇！

ADVANCED MODEL FOR HIGH PRODUCTIVITY

150



自動化整合：
 搭配自動取出機器手臂、自動噴霧機器手臂，提升產能，穩定鑄件品質，節省人力成本。

TOTAL SOLUTION:
 Integrated with Spraying Robot and Extracting Robot, highly improving production efficiency and stabilizing casting quality. Better solution for labor costs reduction.

低速多段射出：
 射出過程熔湯穩定，加速避免捲氣，大幅降低鑄件砂孔率，低速轉高速僅需 0.012 秒。

MULTI LOW SPEED INJECTION:
 Stable molten distribution. Eliminating air entrainment, effectively enhance quality and lower porosity. Injection speed from low to high: 0.012 sec.



自動壓送機：
 稀釋倍率設定容易，調整範圍大，提供液位下限檢知功能警報。

RELEASE AGENT DILUTOR:
 Wide ranged dilution rate with constant concentration. With liquid level detecting functions for insufficient release agent and excessive diluent conditions.

自動拆大柱機構：
 上下模時更加方便快速。

AUTO TIE BAR PULLER:
 Easy to operate and convenient to change particular molds.



生產數據管理：
 射出履歷詳記射出參數，高速誤差落在 3%~5%。搭配不良品檢知、捨打模式，提升智能化生產設備。

DATA MANAGEMENT ASSISTANCE:
 Injection data display, abandoned cast setting and defect detecting system. Upgrade intelligent production equipment.



射出性能：
 獨特迴路設計，結合雙壓缸，強化射出表現，高速每秒可達 7 米。

INJECTION:
 With dual hydraulic system and independent intensification accumulator, enhance injection performance. Injection speed of 7m/sec.

電磁爐：
 節能省電，符合環保法規，熔解效率高、保溫。

ELECTROMAGNETIC INDUCTION FURNACE:
 Environmental compliance and energy-saving. High melting efficiency and heat preservation.



進階選配項目 OPTIONAL FEATURES



數位鎖模力顯示
 鎖模力可設定上下限以保護機械及模具。

DIGITAL CLAMPING FORCE DISPLAY:
 Upper and lower limit of strain values can be set to protect the machine and molds.



節能系統
 節能電路及馬達，經實際生產測試，耗電量下降 30%

ENERGY SAVING SYSTEM:
 Specially designed electric circuit lowers the power consumption by 30%.



遠端數據管理
 經由 HUB 連線多台尚富壓鑄機，傳送詳細生產資料：低速、高速、增壓壓力、循環時間等客製化數據。即時監控場內各機台生產情形。

REMOTE DATA CONTROL:
 Smart scheduling for manufacturing by connecting multiple TBC die casting machines via HUB to transfer production data.



真空機
 搭配模具設計，使模腔內接近真空狀態。採用人機介面控制。

VACUUM MACHINE:
 With Designed mold to enable the cavity near vacuum status. Controlled by HMI.

MACHINE SPECIFICATIONS

ITEM		150	180	280	420	580	730	900					
		V / CF		V / CF / CH			V / CF / CH			CF / CH			CF / CH
Die Locking Force	KN	1500	1800	2800	4200	5800	7300	9000					
Die Platen Dimensions (HxW)	mm	730 x 730	790 x 790	850 x 904	956 x 1010	1090 x 1180	1230 x 1230	1400 x 1400					
Space between Tie Bars	mm	460 x 460	482 x 482	584 x 584	652 x 652	750 x 750	852 x 852	931 x 931					
Tie Bar Diameter	mm	90	110	125	150	160	190						
Die Stroke	mm	350	380	420	560	660	760						
Die Thickness	mm	250 ~ 500	250 ~ 600	300 ~ 700	350 ~ 850	350 ~ 900	400 ~ 950						
Solenoid Valve for Core	Piece	3/8" x 1	3/8" x 1	3/8" x 1 3/8" x 2	3/8" x 1 3/8" x 2	1/2" x 2	1/2" x 3	1/2" x 3					
Hydraulic Outlet	Set	1/2" x 2	1/2" x 2	1/2" x 2 1/2" x 3	1/2" x 2 1/2" x 3	3/4" x 3	3/4" x 5	3/4" x 5					
Injection Force	KN	182	265	354	506	550	653						
Plunger Stroke	mm	330	370	425	580	670	750						
Plunger-Tip Projection Distance	mm	150	150	165	250	300	350						
Injection Port Position	mm	-100	-125	-150	-175	-175	-250 or -275						
Dry Shot Speed	m/s	5	7	5 7 8	5 7 8	7 8	7 8	7 8					
Plunger-tip-Diameter	mm	45 50 60	50 60 70	60 70 80	70 80 90	70 80 90	80 90 100						
Maximum Casting Pressure	Mpa	110.2 45 61.7	132.8 92.3 67.7	109.9 80.6 61.7	117.7 90 71.1	140.5 107.7 85.1	130 102.8 83.1						
Casting Area	cm²	133 165 238 207 257 370	184 265 361 287 413 563	312 425 555 485 661 864	416 544 688 624 816 1033	462 604 764 582 760 962	653 826 1022 904 1144 1414						
Actual Shot Weight	Kg	0.31 0.39 0.56 0.92 1.16 1.67	0.47 0.67 0.92 1.40 2.02 2.75	0.78 1.07 1.40 2.35 3.20 4.18	1.45 1.89 2.40 4.35 5.68 7.19	1.67 2.2 2.78 5 6.6 8.3	2.43 3.07 3.8 7.3 9.2 11.4						
Ejection Force	KN	100.9	123.5	190.1	259.7	300	340						
Ejection Stroke	mm	80	80	100	110	125	125						
Hydraulic Motor	kw	15	18.5	22.5	37	37	45						
Amount of Hydraulic Fluid	L	360	370	480	700	800	860						
Amount of Cooling Water for Oil Cooling	L/min	25	25	25	80	80	150 ~ 180						
Amount of Cooling Water for Die Casting Cooling	L/min	25 ~ 50	25 ~ 50	25 ~ 50	50 ~ 90	50 ~ 90	150						
Machine Weight	ton	5	9.4	12.8	23	30	50						
Machine Size	mm	4820 x 1520 x 2585	5613 x 1650 x 2616	6275 x 1835 x 2975	7590 x 2065 x 3345	8046 x 2335 x 3413	9990 x 2450 x 3556						

TBC reserves the right for adjustment of data.
 Specifications & contents are subject to change without further notice.
 All photos and contents are copyrighted by TBC.

PLATEN LAYOUT

SD-180

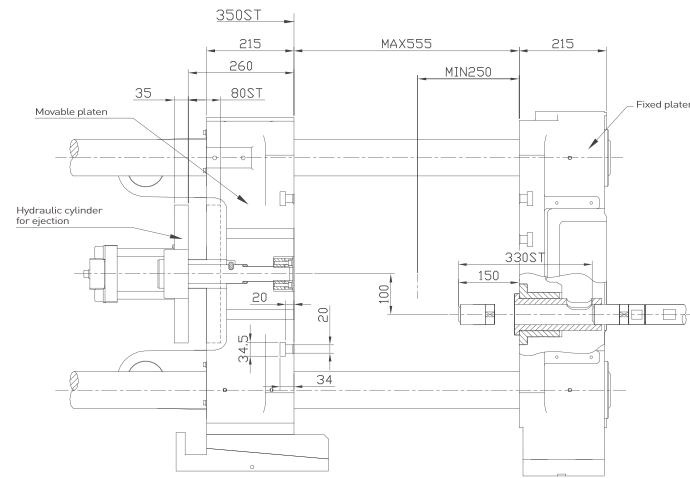
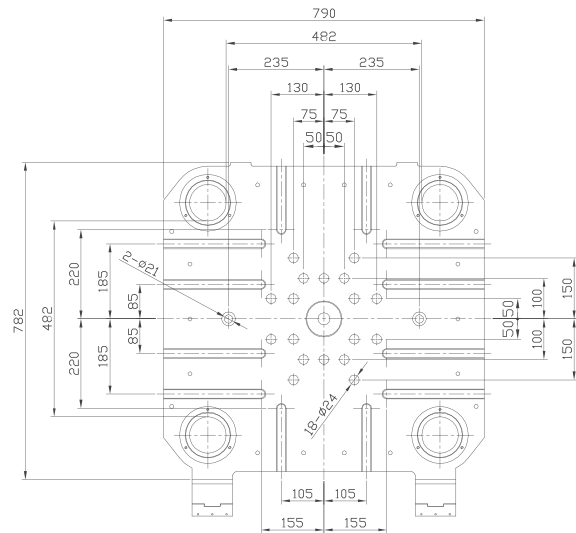

SD-580

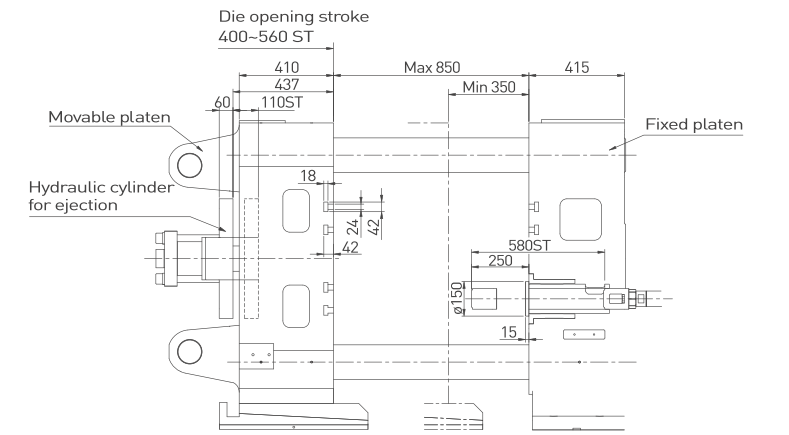
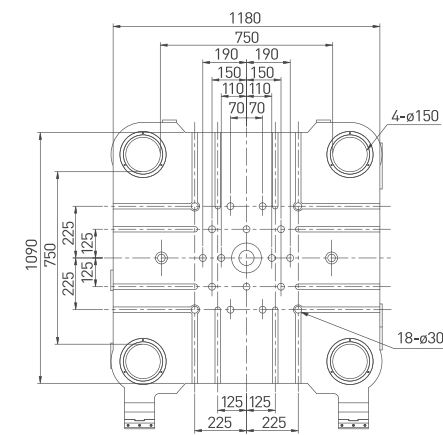

SD-280

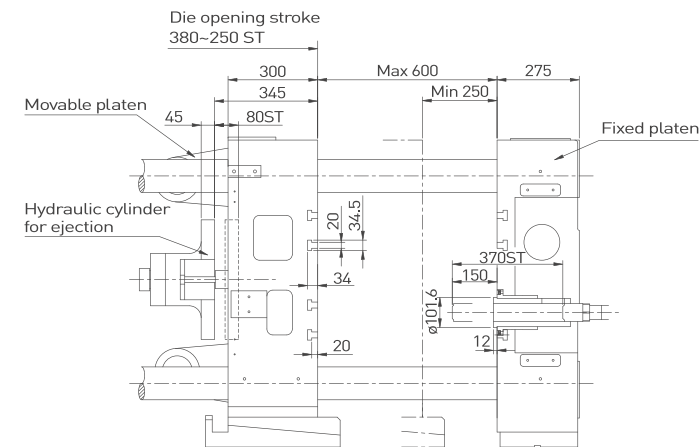
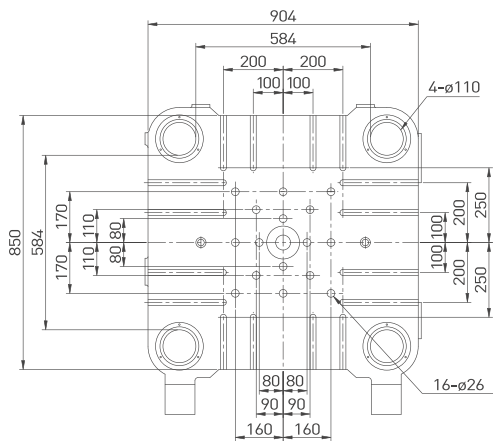

SD-730

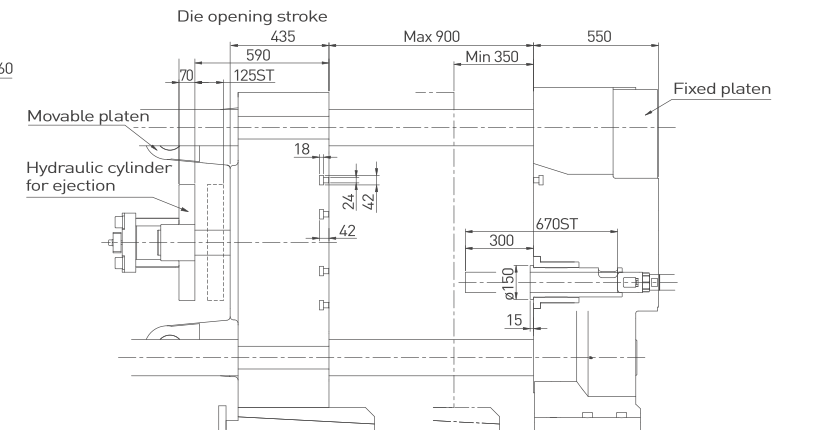
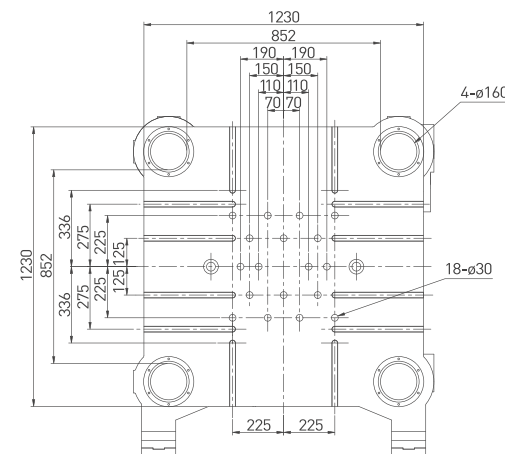

SD-420

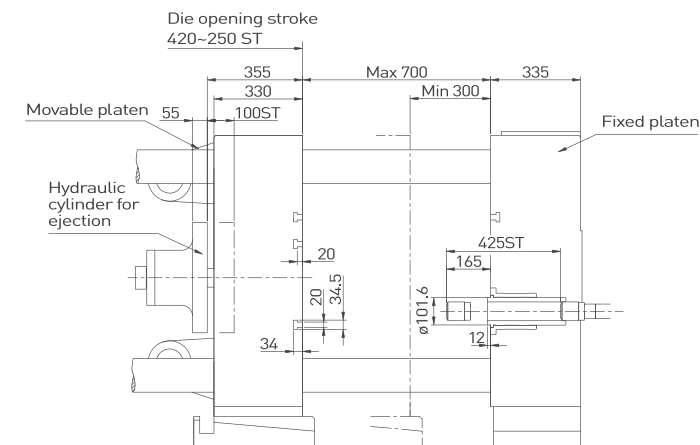
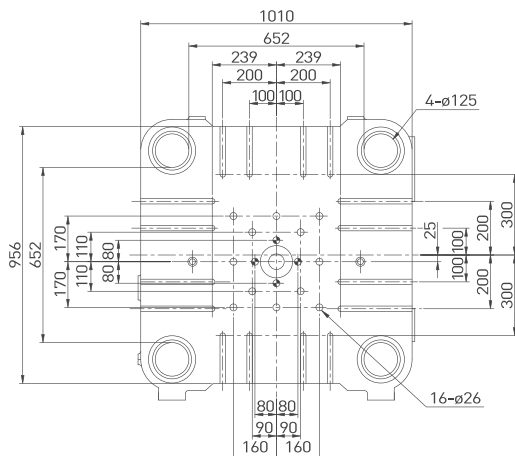

SD-900

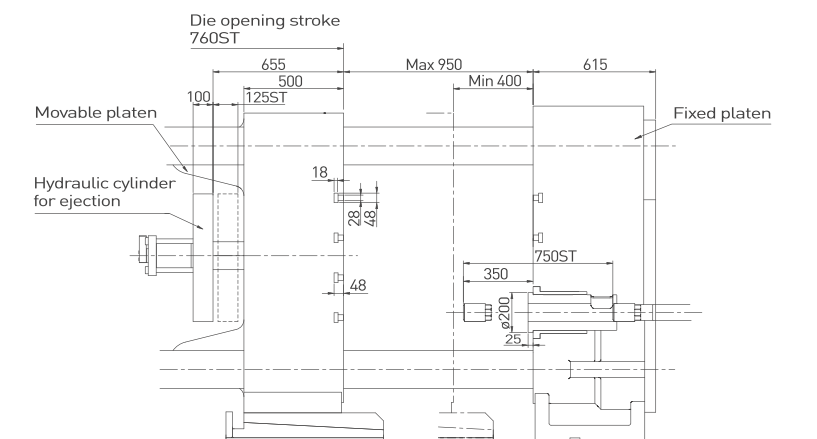
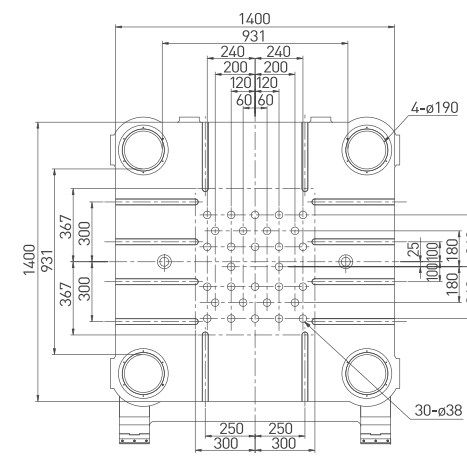

OPTIONAL FEATURES

● : Standard ○ : Optional



ELECTRIC CONTROL

■ **Digital Clamping Force Display:**
Clamping force is displayed on HMI. Upper and lower limit of strain values can be set to protect the machine and molds.

● CH Series ○ CF Series ○ V Series



ELECTRIC CONTROL

■ **Abandoned Casting Setting (Warm-Up Mode):**
During the warm-up mode, the machine can operate in automatic production with a preset number of low-speed injections based on time settings. This prevents the risk of molten aluminum splashing in high-speed injection when the mold temperature is still too low.

● CH Series ● CF Series ○ V Series



ELECTRIC CONTROL

■ **Defective Casting Detector:**
Set upper and lower data limits to monitor each shot and ensure it stays within the specified range. If the data exceeds the limits, the system will trigger an alarm or shut down the machine according to setting.

● CH Series ● CF Series ○ V Series



ELECTRIC CONTROL

■ **Air-conditioner for Control Panel:**
Effectively removing heat and humidity from the panel.

○ CH Series ○ CF Series ○ V Series



ELECTRIC CONTROL

■ **Automatic Safety Door:**
The motor system is controlled by a variable frequency drive (VFD), offering greater stability compared to traditional pneumatic systems. The safety door automatically opens and closes in sync with machine operation.

○ CH Series ○ CF Series ○ V Series



ELECTRIC CONTROL

■ **Security Lock System:**
Prevents the machine from unauthorized access or intentional modification.

○ CH Series ○ CF Series ○ V Series

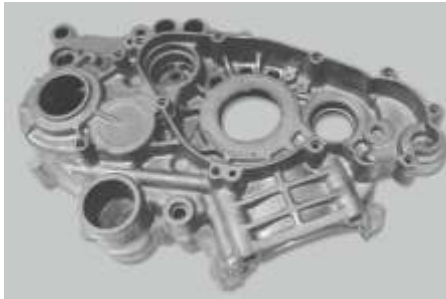

ELECTRIC CONTROL

■ **Vacuum System Interface:**
In combination with a vacuum system and mold design, vacuuming can be achieved directly by setting the parameters on the HMI.

○ CH Series ○ CF Series ○ V Series



MECHANISM

■ **Quick Mold Change System:**
With the use of specialized hydraulic clamps, mold changes become quick and convenient. The operation settings can also be integrated into the HMI of the TBC machine.

○ CH Series ○ CF Series ○ V Series



MECHANISM

■ **Extra Cores:**
Cores can be added up to 6 according to each machine model.

○ CH Series ○ CF Series ○ V Series



MECHANISM

■ **Movable Platen Reinforcement Board:**
Prevents platens from deformation over long-term use.

○ CH Series ○ CF Series ○ V Series

OPTIONAL FEATURES

● : Standard ○ : Optional



MECHANISM

- Auto Tie Bar Puller: 350 ton and above
Easy to operate and convenient to change particular molds.

○ CH Series ○ CF Series ○ V Series



MECHANISM

- Energy Saving System:
Specially designed electric circuit lowers the power consumption by 30%
Example (in Taiwan):
(350T Model, cycle time 30sec, price of electricity in Summer: 3.5 NTD / kWh)
Without ES system: 12 kW/h, With ES system: 8 kW/h, Cost reduction per month per factory: 20,000
 $4\text{kW} / \text{h} \times 10\text{h} \times 25\text{day} \times 20\text{set} = 20000$

● CH Series ○ CF Series ○ V Series



MECHANISM

- Fixed Side Spray: 150-350 ton
Enhancing the spraying process to be more thorough.

○ CH Series ○ CF Series ○ V Series



MECHANISM

- Customized Coloring:
Machine color can be customized if desired.

○ CH Series ○ CF Series ○ V Series



MECHANISM

- Low Hydraulic Oil Alarm:
Sends an alarm when oil level is below minimum levels.

○ CH Series ○ CF Series ○ V Series

Release Agent Dilutor

AUXILIARY



SF-25B



SF-65A

Features

1. Rate of dilution settings is easy to set, the adjustment range is large, and the concentration is stable.
2. Stainless-steel-made mixing buckets and diaphragm pump provide large flow with stable pressure.
3. Level limit detection designed for the release agent bucket and the mixed diluent bucket.
4. Easy maintenance.

SPECIFICATIONS		SF-25B	SF-65A
Applied to Auto Sprayer	-	SS-15 / 35 (4 sets) SS-65 / 80 (2 sets)	SS-15 (10 sets) SS-35 (8 sets) SS-65 / 80 (6 sets)
Dilution Rate	-	50 ~ 416	60 ~ 500
Tank Volume	L	38	200
Maximum Flow Rate of Pump	L / min	159	159 x 2
Air Consumption	L / min	200	200 x 2
Dimension	mm	850 x 600 x 1050	1250 x 900 x 1350
Net Weight	Kg	83	200
Air Pressure: 5Kg / cm ² Output Pressure: 2-5Kgf / cm ²		Water Input Pressure: 2-3Kg / cm ² Water Temperature: 5°C-40°C	

AUXILIARY

GENERAL SPECIFICATIONS - Power Voltage : AC220 / 380V , Operate Voltage : DC24V
 With auxiliaries only, control cabinet is necessary. It can provide an abnormal message alert.
 Easy to use.

Auto Ladler

A Type ▶



FEATURES

- Accurate molten amount supply.
- Inverter driven arms providing smooth and steady movement.
- Easy setting of time and speed.
- Special design of sleeve for long duration under conditions of high temperature and low oil supply.
- Type C is for TBC machines only. Movement is more stable and quicker. More durable.

SPECIFICATIONS		SL-15A / C	SL-35A / C	SL-65A / C	SL-80A / C
Applied D.C.M.	ton	100 ~ 200	250 ~ 420	500 ~ 730	800 ~ 900
Ladle Volume	Kg	0.2 ~ 2.0	0.4 ~ 4.5	4.0 ~ 6.0	4.0 ~ 8.0
Ladle Size	Kg	0.4 / 0.8 / 1.6	1.6 / 2.5 / 3.5	4.0 / 6.0	6.0 / 8.0
Cycle Time	Sec.	12	16	16	18
Min. Crucible Dia.	mm	450	500	650	700
Arm Motor	KW	0.4	0.4	1.5	1.5
Ladle Motor	KW	0.4	0.4	0.75	0.75
Ladle Depth	mm	350	480	550	550
Machine Weight	Kg	229	249	405	398

- Optional for other ladle size.

◀ C Type



Auto Extractor

FEATURES

- Inverter driven arms providing steady and fast movement.
- Firm grip of castings without vibrating or slipping.
- Water-proof, dust-proof and splash-proof structure design.
- Detecting the number of castings extracted, function available.
- Servo Extractor can be optional, providing more efficient and flexible operation.

SPECIFICATIONS		SE-15C	SE-35C	SE-65C	SE-80C
Applied D.C.M.	ton	100 ~ 200	250 ~ 420	500 ~ 730	800 ~ 900
Extract Stroke	mm	960	1199	1890	2167
Drag Stroke	mm	150	200	300	300
Adjustment For Die Thickness	mm	±100	±100	±100	±100
Clamping Dia.	mm	40 ~ 70	50 ~ 80	70 ~ 95	80 ~ 120
Machine Weight	Kg	233	285	460	530

Clamp Withdraw : 90° Revolve Degree : 90° Air Pressure : 5Kg/cm²



Auto Sprayer

FEATURES

- Unique circuit design for excellent spray atomization.
- Timer and flow valve controlled spray volume which is easy for optimization.
- High flexibility of tubes for directional adjustment. Suitable for any kind of mold.
- Easy tube base substitution and tube numbers adding / removing.
- Equipped with independent pneumatic circuit to dry out the residual release agent.
- Auto-locked upper position limit under condition of pneumatic source stopping.

SPECIFICATIONS		SS-15 / 15BM	SS-35 / 35BM	SS-65 / 65BM	SS-80 / 80BM
Applied D.C.M.	ton	100 ~ 200	250 ~ 420	500 ~ 730	800 ~ 900
Up-down Stroke	mm	600 / 650	700 / 800	900	1000
Adjustment For Die Thickness	mm	180	180	280	300
No. of Spray Tubes		26	40~ 50	63	75
No. of Air Tubes		8	8	12	12
Air Consumption	LPM	1400	1500	2500	2500
Lubricant Pressure	Kg/cm ²	3 ~ 5	3 ~ 5	3 ~ 5	3 ~ 5
Machine Weight	Kg	190	200	267	253

Revolve Degree : 90° Air Pressure : 5Kg/cm²

Servo Sprayer

FEATURES

- Contains all the advantages of the normal sprayer.
- Uses servo motor with high durability bearings driving the sprayer allowing fast up/down movements and saving energy.
- Highly efficient spraying with the ability for fine vertical movements.
- Able to reduce usage of release agent by 50~70%.
- Able to shorten the cycle time by 1~5 secs.
- Able to enhance product quality by lowering porosity.
- **Optional for Standard Type / Link Type servo sprayer.**

◀ Standard Type



▶ Link Type

AUXILIARY



Auxiliary

Spraying Robot

- Specialized independent nozzle control for air and release agent. Adjustable for quantity of spraying.
- Able to adapt to hard to reach angles.
- Dust and water resistant.
- Spraying parameter stored and is not required copper tubes.
- Able to extend storage space by USB.
- Reduce labor cost.



Auxiliary

Extracting Robot

- Able to be integrated with casting inserts.
- If combined with stamping press/conveyor, improving production efficiency.
- Able to be integrated with Defective Casting Detector, automatically picking out bad castings.



Auxiliary

Extracting and Spraying (2 in 1) Robot

- Specifically applicable to hot chamber die casting machine.
- Able to adapt to hard to reach angles.
- Fluent movement of spraying and extracting, saving labor cost.

OTHERS DIE CASTING AUXILIARIES



Auxiliary

Vacuum System

- Equipped with HMI, user-friendly, easy to operate.
- Improve density of the casting, decrease surface flow marks and porosity, and increase qualified rate of casting
- **The casting has a good surface suitable for painting/electroplating.**

MODEL	
Applied to D.C.M	800 ton below
Nominal Displacement of Vacuum Pump	63m ³ /Hr(50Hz, 76m ³ /Hr(60Hz)
Nominal Motor Rating of Vacuum Pump(KW)	1.8KW(50Hz),2.2KW(60Hz)
Volume of Tank (L)	150L
Dimension(mm)	1150mm(L)x600mm(W)x1150mm(H)



Auxiliary

Auto Charging System

- Simplifying the process of manual feeding.
- Increasing efficiency of production.
- Able to adjust speed, time, and quantity of distribution.
- Standard for warning light, buzzer, and safety door.

MODEL	SPA-80	SP-50C
Molten Metal	Aluminum	Zinc
Max. Speed	45 m/min	45 m/min
Ladle Speed	95 mm/sec	95 mm/sec
Ladle Volume	60KG	50KG
No.ofmachine	12sets	12sets

TOTAL SOLUTION FOR HOT CHAMBER DIE CASTING MACHINE



Extracting and Spraying (2 in 1) Robot

- Fluent movement of spraying and extracting, saving labor cost.



Conveyor



Auto Sprayer / Extractor



Auto Charging System

Customized Coloring



Video: TH-190 + Robot

MODEL & SERIES

HOT CHAMBER DIE CASTING MACHINE / 75 / 130 / 190 / 250 ton



HIGH QUALITY MACHINES TO SATISFY YOUR DIE CASTING NEEDS

Rigid & Durable, Steady Mechanism Design.
User Friendly Interface, Easy to Operate.

INJECTION SYSTEM



- Controlled by Proportional solenoid valve
- Excellent injection intensity.
- Precise control to enhance component quality.

INJECTION SYSTEM

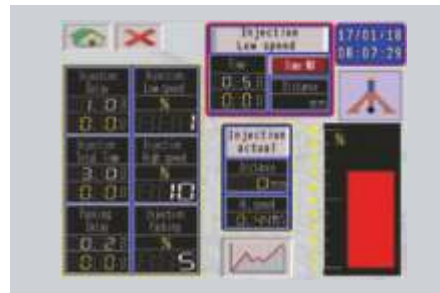

- Three-phase injection mechanism
- Provides low, high speeds and pressure retention.
- Enhanced air-tightness during pressure retention period.

PLATEN SYSTEM



- Proportional Solenoid Valve
- Smooth die close / open.
- Short die close / open cycle.

TWO MODES IN LOW SPEED CONTROL

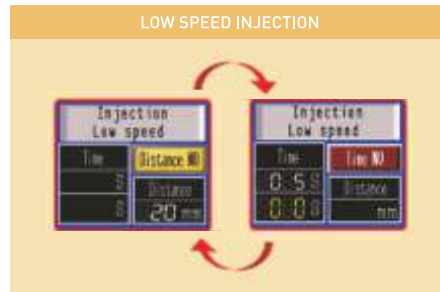

- Freely switch between time / distance in low speed injection modes.
- Effectively control the pressure and speed of injection with measured values provided.

OVER 30 YEARS OF EXPERIENCE WITH DIE-CASTING MACHINES

We have over 30 years of R&D experience in the cold-chamber die-casting machine industry. Enabling us to produce easy-to-use, robust and stable hot-chamber die-casting machines.



MAINTENANCE & MANAGEMENT

- Data Management
- Up to 250 sets of casting conditions able to be stored.
- Enhance management efficiency.
- Error message display
- Abnormal message alerts for quick troubleshooting.



COMPLETE INJECTION DATA DISPLAY

- Three curves displayed in the figure: Pressure, Distance and Time.
- Injection data will be displayed on the screen for further usage.

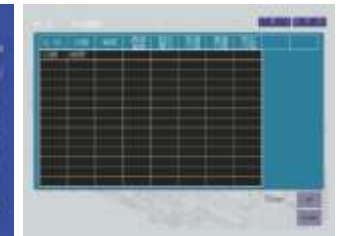



TBC Hot chamber die casting machine video link.

PLATEN LAYOUT

TH-75

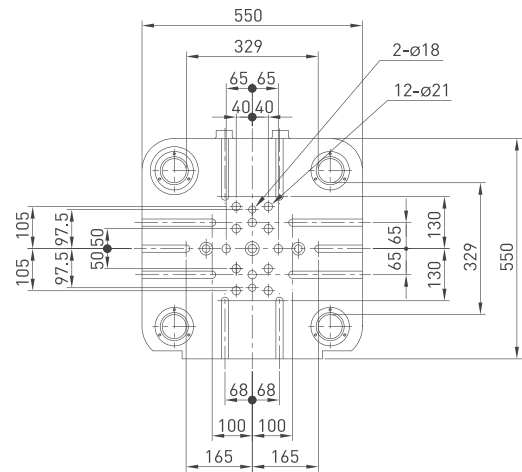

TH-190



TH-130

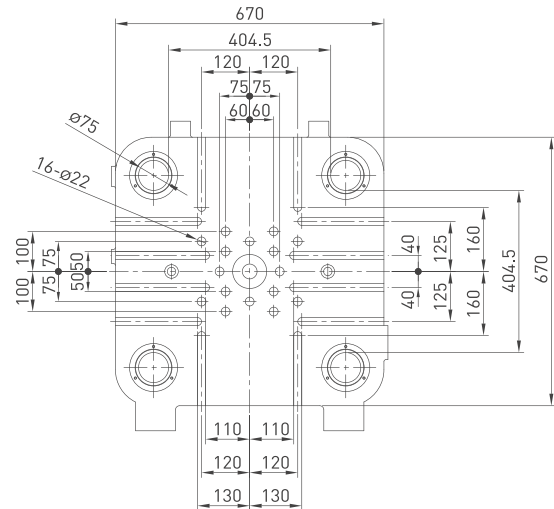

TH-250

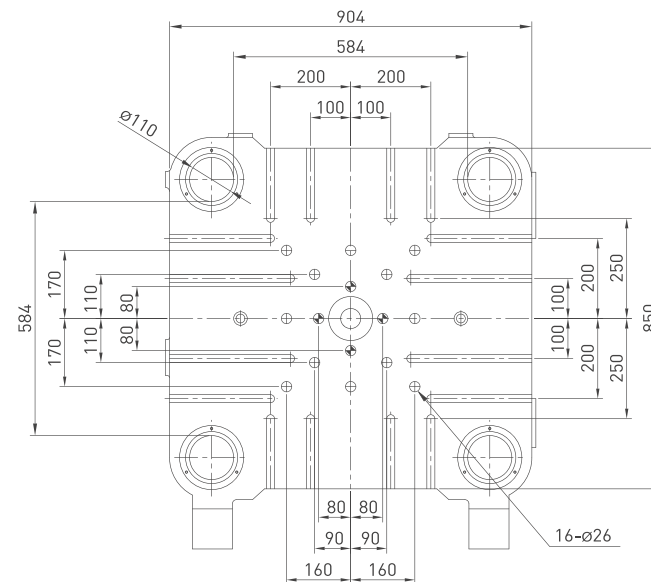

MACHINE SPECIFICATIONS

MODEL	UNIT	TH-75	TH-130	TH-190	TH-250
PLATEN PART					
Die Clamping Force	ton	75	130	190	250
Tie Bar Diameter	mm	60	75	90	110
Die Platen Dimensions (HxV)	mm	550 x 550	670 x 670	730 x 730	850 x 904
Space between Tie bars	mm	329 x 329	404.5x404.5	460 x 460	584 x 584
Die Stroke	mm	210	310	350	380
Die Thickness	mm	120~400	140~480	150~500	200~600
Nozzle Matching Force	ton	5.1	6.0	7.5	13.0
Nozzle Stroke	mm	200	200	200	250
INJECTION PART					
Injection Cylinder Diameter	mm	80	100	120	120
Maximum Injection Force	ton	5	7.85	10	12.5
Maximum Injection Stroke	mm	125	190	190	200
Injector Rod Diameter (Standard)	mm	50	60	65	75
Actual Shot Weight (Zinc)	g	1200	2500	3000	4500
Furnace Capacity (Zinc)	kg	260	500	500	700
Injection Position	mm	0, 60	0, 80	0, -100	0, -150
Maximum Casting Area	cm ²	253	494	615	929
Casting pressure	kg/cm ²	256	200	238	269
EJECTION PART					
Ejection Force	ton	5	6	7.5	10.5
Ejection Stroke	mm	70	70	80	100
HYDRAULIC PART					
Operating Pressure	kg/cm ²	110	110	110	125
Accumulator (HYDAC) N2 (Injection)	l/ea	20 x 1	20 x 2	20 x 2	32 x 2
Accumulator (HYDAC) N2 (Die close)	l/ea	10 x 1	20 x 1	32 x 1	50 x 2
Oil Tank Capacity	l	200	400	600	800
ELECTRICAL PART					
Electrical Motor	kw	11.0	15.0	18.5	30.0
MACHINE SIZE					
Machine Weight	ton	5	7.5	10.5	14.7
Machine Size	m	4.2x2.0x1.8	4.3x2.2x2.3	4.8x2.1x2.5	5.5x2.2x2.6

Option	
Auto Safety Door	Auto Hydraulic Injection Position Adjustment.
Electric Heater for Shot Sleeve	Extracting and Spraying (2 in 1) Robot
Nozzle -Type Sprayer	Electric Melting Furnace
Auto Extractor	Conveyor

TBC reserves the right for adjustment of data. Specifications & contents are subject to change without further notice. All photos and contents are copyrighted by TBC.



TECHNOLOGY BASE CORPORATION

No.21, Heye 1st Road., Ho Fa Industrial Park, Daliao District, Kaohsiung City 83164, Taiwan
T. +886-7-7873627~8
F. +886-7-7872262
info@tbc-diecast.com

TBC GOLDCOIN PVT. LTD.

776, GIDC INDUSTRIAL ESTATE G- Road, Makarpura, Vadodara, Gujarat, India
T. +91-265-2632210
M. +91-9904805251
techbase@163.com



OVERSEA SERVICE SPOT

China : Fujian, Xiamen, Jiangsu, Kunshan, Ningbo
India : Delhi, Pune, Coimbatore, Chennai
Indonesia : Jakarta, Surabaya
Vietnam : Ho Chi Minh City, Hanoi
South Korea : Seoul
Malaysia: Kuala Lumpur
Thailand: Bangkok
Pakistan: Karachi

TBC reserves the authorization for modification.
Specifications & contents are subject to change without further notice.
Copyright of all photos, contents are belong to TBC.

